

# ***Color Video Camera Module***

---

**Technical Manual**



**XC-505/505P**

---

# Table of Contents

---

## Overview

Main Features.....	3
Connection Diagram.....	4
Location of Parts and Operation .....	7
Mode Setting by Dip Switch.....	8
Installation.....	10
Connections .....	11
Genlock.....	12

---

## RS-232C Command List

RS-232C Connector Pinouts.....	13
Communication Specifications .....	14
Camera Control Command List.....	16
Camera Control Commands .....	18

---

## Appendix

Camera Control Command List.....	27
Specifications .....	31
Dimensions .....	32
Spectral Sensitivity Characteristics (typical).....	33

The XC-505/505P is a small color video camera module that incorporates a 1/3-type IT CCD.

---

## Main Features

---

### Small Size and Lightweight

The camera is so small and light that you can install it anywhere: even in locations where conventional video cameras cannot be installed.

---

### High Sensitivity

A built-in Super HAD II (Hole Accumulated Diode II) sensor, allows high sensitivity, low smear images. You can shoot, even under poor lighting conditions.

---

### Simple Configuration via DIP Switch

Gain, shutter speed, and white balance can be configured using the 8-bit DIP switch located on the side of the unit.

---

### Five White Balance Adjustment Settings

Using the white balance DIP switches, you can choose from among five white balance modes (3200K/5600K/One Push WB/ATW/MAN) to choose the best settings for shooting conditions, and the most appropriate color compensation.

---

### Electronic Shutter with a Wide Range of Operating Speeds

Using the electronic shutter DIP switches, these levels of shutter speed (OFF, 1/1,000, and FLICKERLESS) are

available to allow you to match the shutter speed to the shooting conditions.

When you set the DIP switches for the CCD IRIS function, the shutter speed is adjusted automatically, based on the amount of light allowed to enter, ensuring the most appropriate level of image signal.

Advanced settings can be configured via RS-232C serial communication. For details, see “Communication Specifications” on page 14.

---

### Function Setting via RS-232C Transmissions

Using computer communications software such as HyperTerminal and Tera Term, function switching can be performed.

A variety of functions such as NR (2D/3D), edge enhancement,  $\gamma$ , Nega/Posi, and Flip can be set via serial communication. For details, see “Communication Specifications” on page 14.

# Connection Diagram

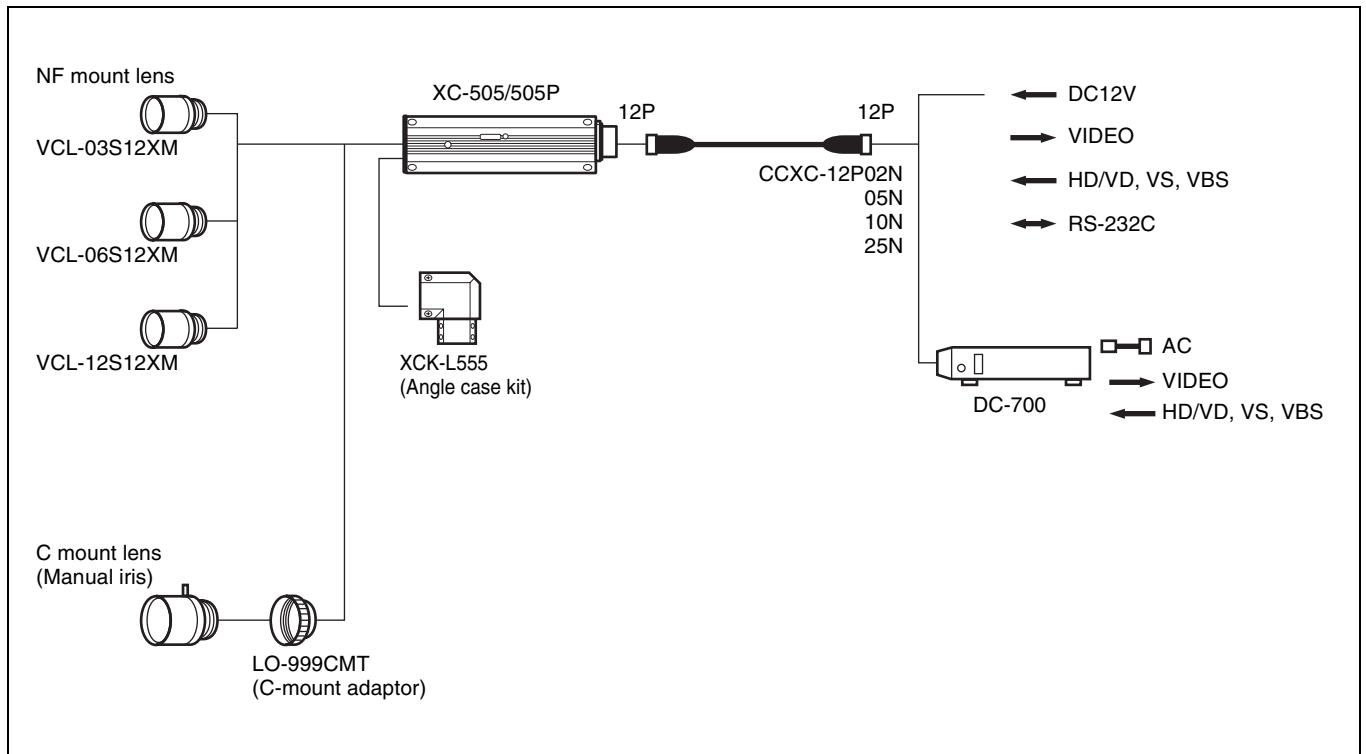

# XCK-L555 Angle Case Kit

The XCK-L555 allows you to bend the XC-505/505P 90 degrees horizontally (HL).

**Note**

You can install XC-505/505P in only HL (horizontal) directions. VL (vertical) is not available with this model.

## Dimensions

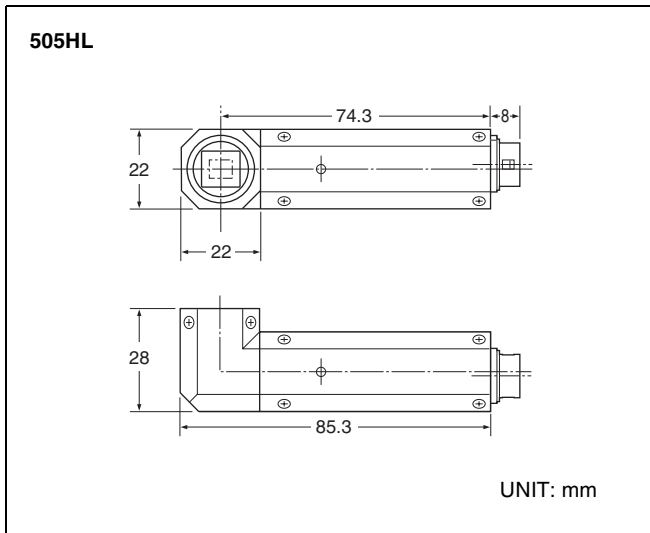

## Angle type

On the upper position of the Front block ● is located. Set the direction correctly while looking at the Front block from the front so that ● is in the upper position. Dip switch: rear

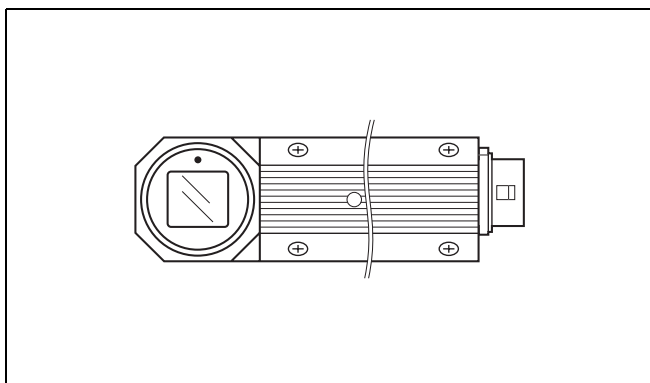

## Installation

Use angle case A/B and screws.

- 1 Remove the four screws (+PM1.7 × 3) from the front panel.

The front block will pop out due to pressure from the flexible cable.

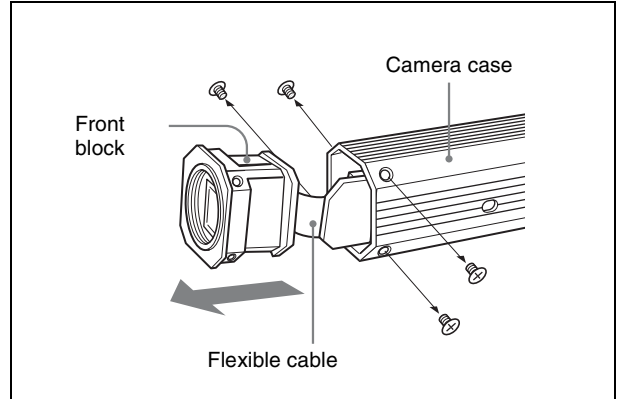

- 2 Attach the angle case (B) to the underside of the front block.

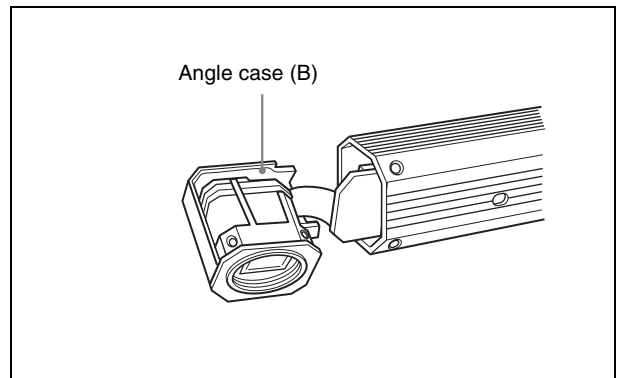

**Note**

Do not pull the front block out forcibly. If you do so, you may damage the flexible cable.

- 3 Attach the angle case (A) to the front block.

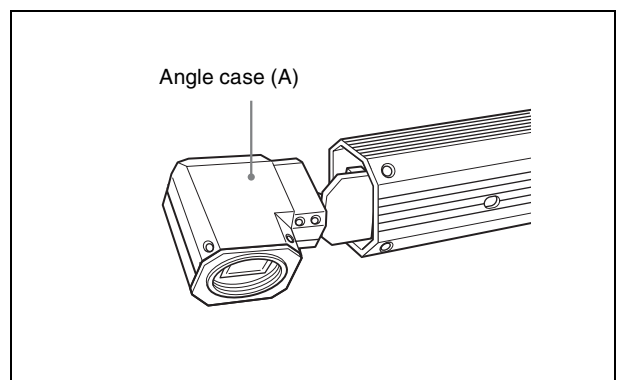

- 4** Insert the front block into the camera case, and attach it securely using the four screws (+PM1.7 × 3) removed in step 1.

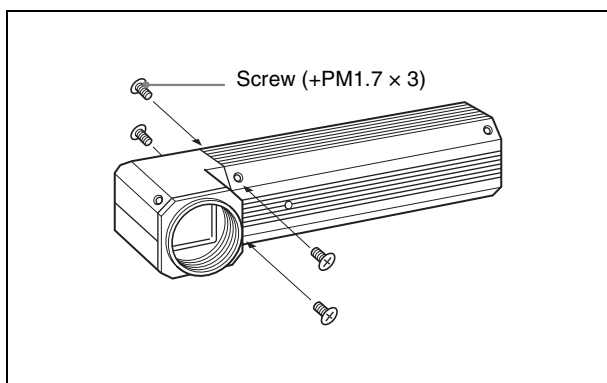

**Note**

Tighten the screws to a torque level of 0.15 N•m for the XC-505/505P.

- 5** Using the four screws (+K2 × 2.5) provided, attach the angle case (A/B) and the front block securely.

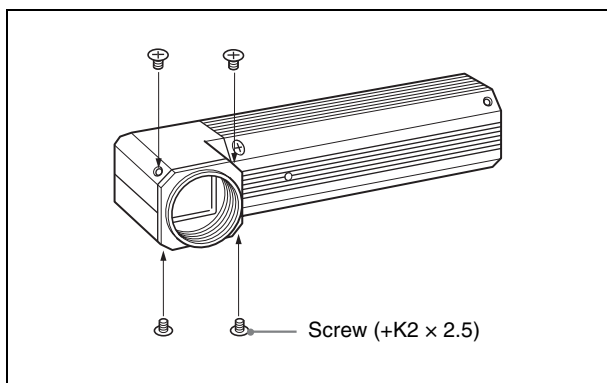

**Note**

Tighten the screws to a torque level of 0.18•Em.

# Location of Parts and Operation

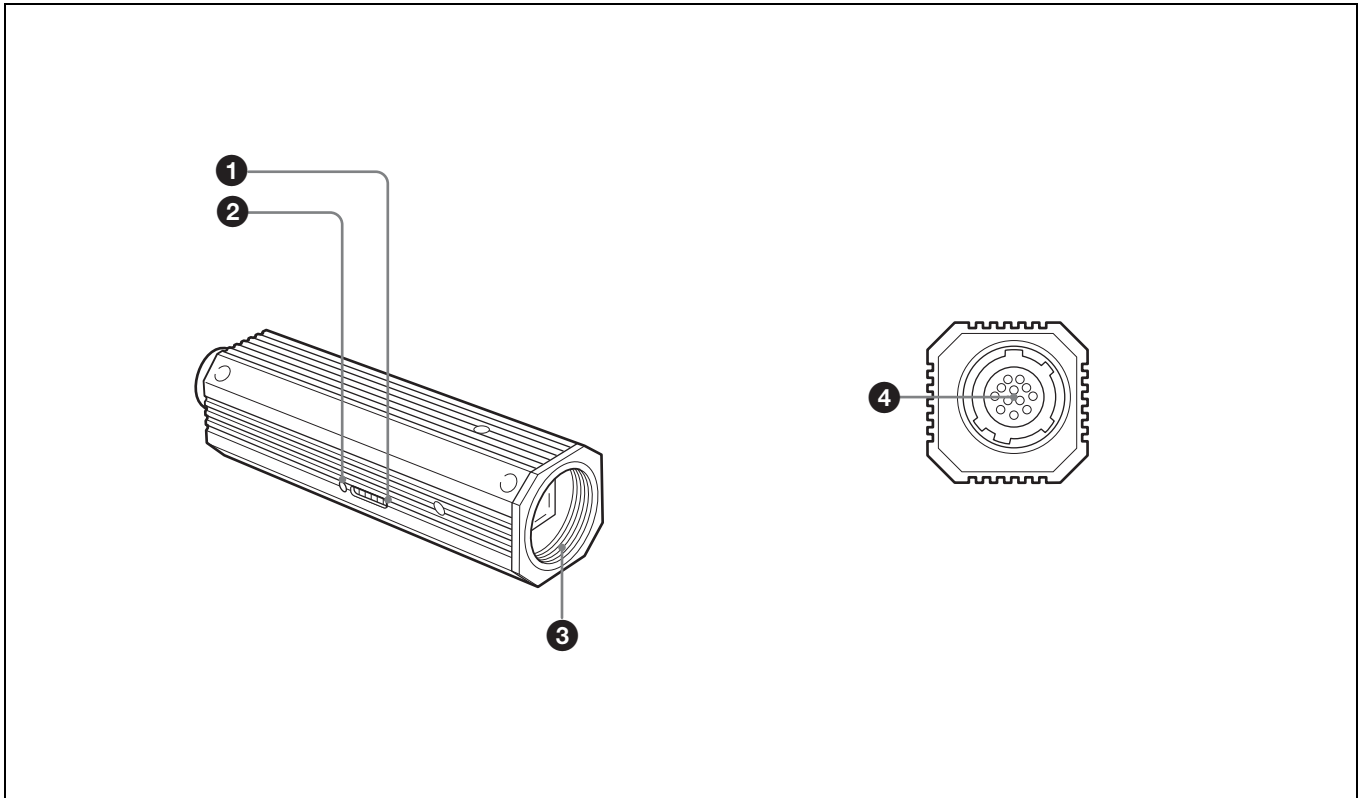

## ❶ Dip switches for setting functions

This switches are used to adjust white balance and shutter speed; and to flip AGC (ON/OFF) and output signals (Y/C/VBS).

For details, see “Mode Setting by Dip Switch” on page 8.

## ❷ One Push WB switch

One Push white balance functions when the white balance adjustment mode is set to One Push WB. The white balance is automatically adjusted when this switch is pressed, and the color balance is retained after adjustment.

## ❸ NF mount

## ❹ DC IN/SYNC/VIDEO connector (multi 12-pin)

This connector inputs DC 12 V power and outputs the video signal when the CCXC-12P02N/12P05N/12P10N/12P25N camera cable is connected.

If the unit is connected to devices that originate a synchronized signal, the external synchronous signal (VS, VBS, HD/VD) can be used to move the color camera module.

VBS signals input as external synchronized signals perform the same functions as VS signals. (Burst signals are not locked and are free running.)

## Pin Assignment of the DC IN/SYNC/ VIDEO Connector

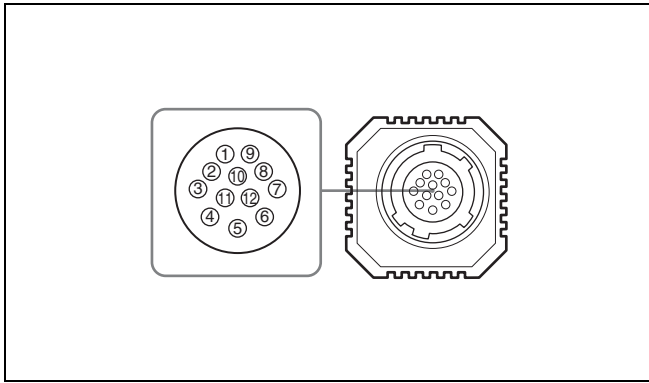

Signal Pin No.	Sync signal types		
	External Sync signal		Internal Sync signal
	HD, VD	VS/VBS Input	
1	GND	GND	GND
2	+12 V	+12 V	+12 V
3	VBS/Y Output (GND)	VBS/Y Output (GND)	VBS/Y Output (GND)
4	VBS/Y Output (signal)	VBS/Y Output (signal)	VBS/Y Output (signal)
5	HD Input (GND)	—	—
6	HD Input (signal)	—	—
7	VD Input (signal)	VS/VBS Input (signal)	—
8	GND (-/C)	GND (-/C)	GND (-/C)
9	-/C Output (signal)	-/C Output (signal)	-/C Output (signal)
10	RS-232C (TXD)		
11	RS-232C (RXD)		
12	VD Input (GND)	VD Input (GND)	GND
	RS-232C (GND)		

## Mode Setting by Dip Switch

By flipping the DIP switches located on the side of this camera, you can adjust the following functions.

### Note

Each switch is assigned to a function. The switches that should be set to adjust a certain function (white balance, shutter speed), to switch the AGC (ON/OFF), or to switch the output signals (Y/C/VBS) are specified and indicated by shading in the illustrations of the corresponding descriptions of the function. The switches that are not shaded are not related to these functions.

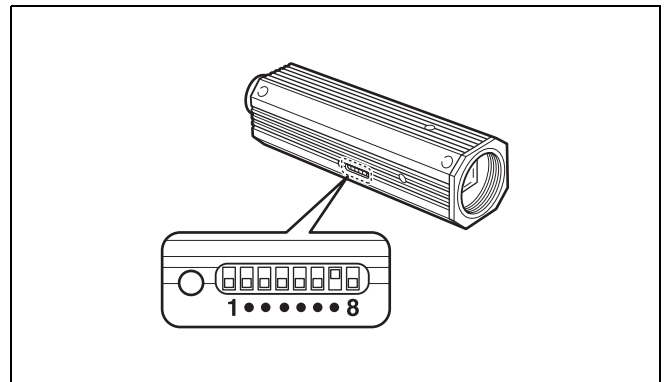

## Factory Settings







White balance: ATW  
 Shutter speed: OFF  
 AGC: ON  
 Output signal (Y/C/VBS): VBS

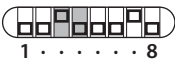

## To Adjust the White Balance

Select the white balance setting according to the lighting conditions.

To adjust the white balance, use bitXX (the shaded switches).

	Lighting condition	DIP switch setting
3200K (fixed)	For indoor shooting under incandescent light.	 1 . . . . . 8
5600K (fixed)	For outdoor shooting on sunny days.	 1 . . . . . 8
One Push WB (One Push white balance)	The white balance is automatically adjusted when the One Push WB switch is pressed, and the color balance is retained after adjustment.	 1 . . . . . 8
ATW (auto tracing white balance)	The white balance is adjusted according to the color temperature transition of the subject. This mode is suitable for shooting with variable lighting (factory setting).	 1 . . . . . 8
MAN (manual)	Manual white balance is adjusted using the DIP switches in combination with the One Push WB switch.	
	Red hues are subdued with each press of the One Push WB switch.	 1 . . . . . 8
	Red hues are enhanced with each press of the One Push WB switch.	 1 . . . . . 8
	Blue hues are subdued with each press of the One Push WB switch.	 1 . . . . . 8
	Blue hues are enhanced with each press of the One Push WB switch.	 1 . . . . . 8

### Note





The correct white balance is obtained when a white subject is shot on the whole detection area.

The correct color reproduction may not be obtained during a normal scene shooting.

## To Adjust the Shutter Speed



Set the shutter speed switches to select the desired shutter speed. Using the CCD IRIS function, set the CCD IRIS mode.

To adjust the shutter speed, use the shaded switches.

	Shutter speed	DIP switch setting
OFF	1/60 sec. (XC-505) 1/50 sec. (XC-505P) (factory setting)	 1 . . . . . 8
1/1000	1/1,000 sec.	 1 . . . . . 8
CCD IRIS	Set the CCD IRIS mode.	 1 . . . . . 8
FLICKERLESS	1/100 sec.	 1 . . . . . 8

## AGC (Auto Gain Control) ON/OFF

To switch the AGC on or off, use the shaded switch.

	Gain	DIP switch setting
ON	Auto gain control (factory setting)	 1 . . . . . 8
OFF	0 dB	 1 . . . . . 8

## To Switch the Output Signals (Y/C/VBS)

Select the camera output signal.

To switch the output signals (Y/C/VBS), use the shaded switch.

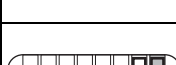
	Output signal	DIP switch setting
VBS	Select this position to output the VBS signal from the DC IN/VIDEO (factory setting).	 1 . . . . . 8
Y/C	Select this position to output the Y/C separated signal from the DC IN/VIDEO connector.	 1 . . . . . 8

# Installation

## Usable Lenses

- NF-mount lens
  - VCL-06S12XM (f=6 mm)
  - VCL-03S12XM (f=3.5 mm)
  - VCL-12S12XM (f=12 mm)

The mounting thread of the NF-mount lens should not extend more than 4.1 mm from the lens mount shoulder (See below).

- C-mount lens  
C-mount lens for 1/3-type sensor (The mounting thread should not extend more than 4.1 mm from the lens mount shoulder) (See below). When a C-mount type lens is attached, a C-mount adaptor (LO-999CMT) is required.

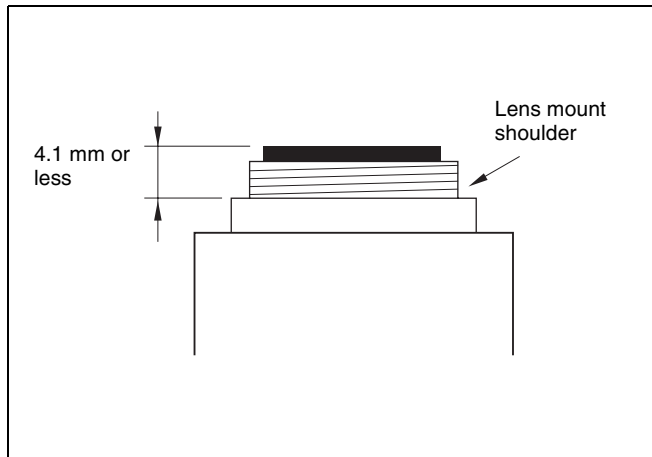

### Notes

- When connecting a heavy lens, make sure that it is supported properly.
- When connecting heavy lens, make sure that it is not subject to shocks or vibration.

## To Attach a Lens

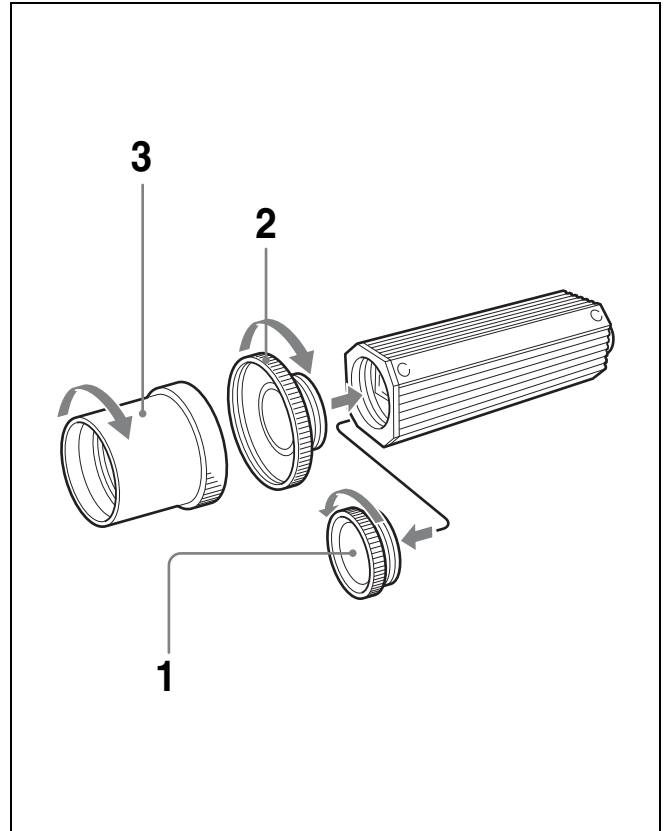

- 1** Remove the lens mount cap by turning it counterclockwise.
- 2** Screw the C-mount adaptor (LO-999CMT) into the lens mount of the camera. (only when using a C mount lens)
- 3** Screw the lens.

## To Install the Camera on a Tripod

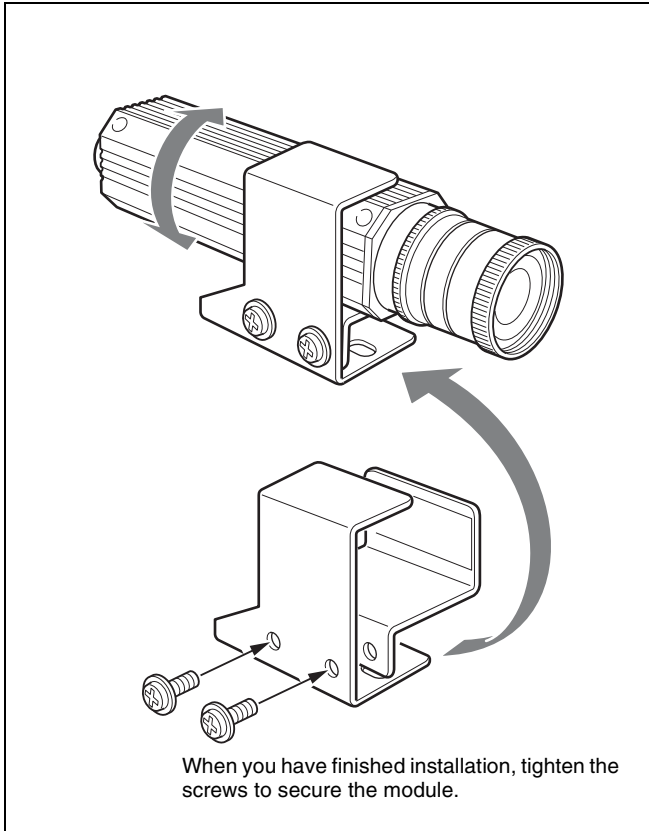

When mounting the camera on a tripod, use the supplied tripod adaptor.

- 1 Assemble the tripod adaptor parts.
- 2 Mount the video camera module on the tripod adaptor.

## Connections

An example of the assembly of the DC-700/700CE Camera Adaptor.

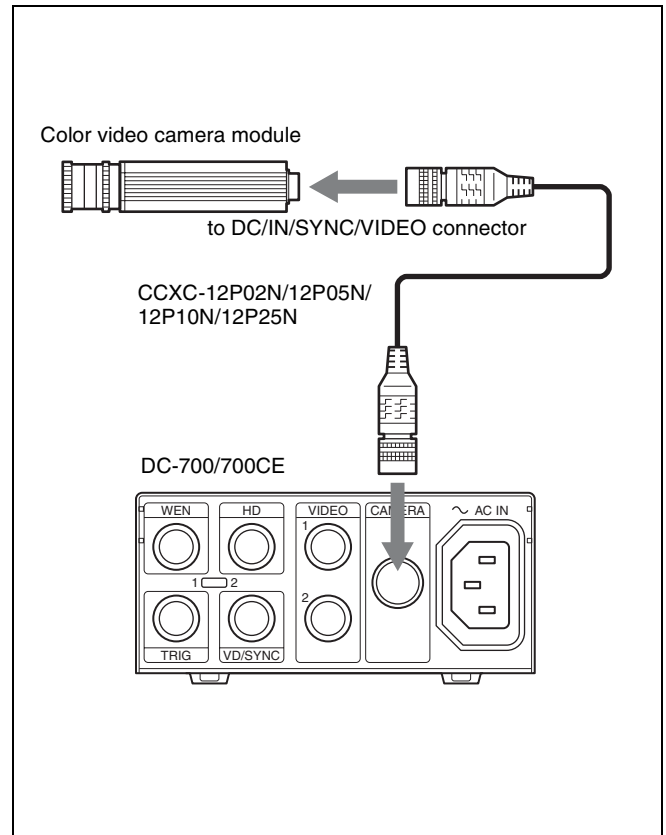

### Notes

- Make sure to turn off the power to the units you are connecting or their components may be damaged.
- When disconnecting the cord, pull it out by the plug. Never pull the cord itself.
- Connect the power cord after completing all other connections.

---

# Genlock

The color video camera module is designed so that internal sync and external sync are switched automatically. When the color video camera module receives the following external sync signal, the camera is synchronized to that external sync signal.

Connection example	External sync signal		
	HD/VD	VS	VBS
Connection of the camera and the DC-700/DC-700CE	Genlock		Genlock (However, burst signals not locked. Same function as VS lock.)

## Note

Use a synchronous signal meeting the specifications given in this Technical Manual. For details on the specifications, see page 31.

# RS-232C Command List

Hardware and software can be damaged by RS-232C control programs developed using this command list. Sony shall accept no liability for any such damage.

You can externally control various camera functions by sending commands via the camera's RS-232C interface. Setting values for various functions can be stored in the camera's internal memory. The non-volatile internal memory preserves data even without power, so you can resume operation with the same settings when power is restored.

## RS-232C Command Usage Precautions

Keep the following in mind regarding the RS-232C TXD and RXD pins:

- Do not apply voltage exceeding  $\pm 10$  V to RXD pin 11 of the 12-pin connector.
- The output voltage on TXD pin 10 of the 12-pin connector is typically within  $\pm 5.4$  V. Do not apply external voltage to this pin.

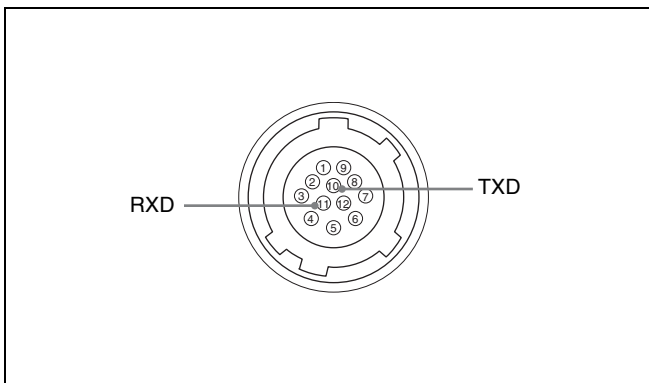

## RS-232C Connector Pinouts

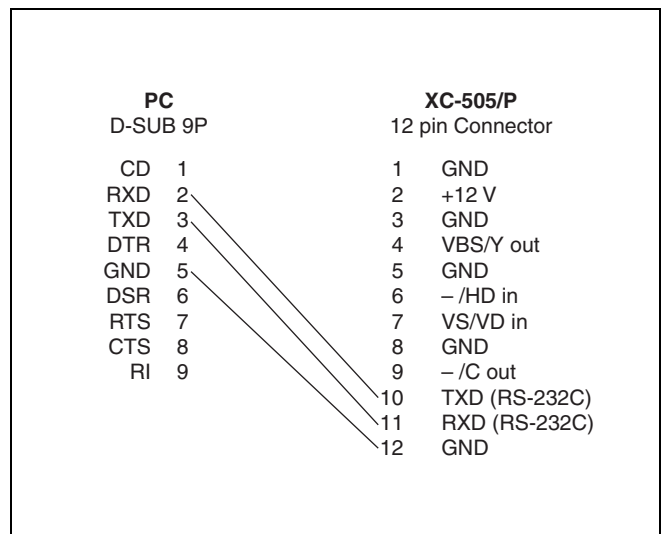

# Communication Specifications

## Serial Communication Specifications

The camera uses an RS-232C-conforming start-stop synchronous serial interface.  
Sent commands are remotely echoed back.

Baud rate: 38400/19200/9600 bps  
Default: 38400 bps  
Data length: 8 bits  
Parity: none  
Stop bit: 1 bit  
Flow control: none

## Command Format

Sent commands, consisting of a command name and appended parameters, are input when followed by a carriage return ASCII code.

### Input syntax

```
command param1 param2 param3 [ENTER]
```

### Input example

```
GAIN-STEP 18<CR>
```

## Command Input and Response Status

### Command Input

The camera accepts the following characters strings as valid.  
When the camera receives a valid character string, it is remotely echoed back.

Item	Character	ASCII Value	Remarks
Alphabets	'A' to 'Z'	0x41 to 0x5A	Strings are not case-sensitive.
	'a' to 'z'	0x61 to 0x7A	
Numerics	'0' to '9'	0x30 to 0x39	-

Item	Character	ASCII Value	Remarks
Symbols	'_'	0x2D	Numerical values may be prepended by a sign character. '+' is allowed, but is ignored.
	'+'	0x2B	
Space	' '	0x20	Not allowed at the beginning of a line.
[BackSpace]	BS (control character)	0x08	none
[ENTER]	CR (control character)	0x0D	none

### Note

Commands may contain up to 64 characters (excluding the ending CR).

## Parameter Entry

Only base-10 (numerical) parameter values are accepted. Valid values depend on the particular input command. Commands with non-decimal parameter characters cannot be processed.

### Example. AE-REF (when received with a base-10 parameter)

<<Accepted normally >>

```
AE-REF 1023<CR>
```

<<Returns the "ERROR PARAMETER" response status>>

```
AE-REF 3FF<CR>
```

<<Returns the "ERROR PARAMETER" response status>>

```
AE-REF ABC<CR>  
AE-REF 1023ABC<CR>
```

## Sign Operators

A "+" or "-" sign may be prepended to a parameter.

<<Accepted normally>>

```
GAIN-FINE +10<CR>  
GAIN-FINE -10<CR>
```

<<Returns the "ERROR PARAMETER" response status>>

```
GAIN-FINE +-10<CR>  
GAIN-FINE 10-3<CR>
```

## Omitted and Extra Parameters

Commands with omitted or extra parameters are ignored. Also, entering a CR without any other input only changes to the next line.

### Example. SSHUTTER command with two parameters

<<Accepted normally>>

```
SSHUTTER 0 1<CR>
```

<<Returns the "ERROR PARAMETER" response status>>

```
SSHUTTER 0 1 1<CR>
SSHUTTER 0<CR>
```

## Response Status

When an input command has finished processing, the camera returns the response status to notify the user whether it succeeded.

<<Input>>

```
AGAIN-STEP 12<CR>
```

<<Screen Output>>

```
ERROR SYNTAX<CR><LF>
```

## Response Status from the Camera

Response Status	Description
OK	OK appears at the end of the screen when command execution finishes normally.
ERROR SYNTAX	Appears when an invalid command name is input.
ERROR STATUS	Appears when command execution fails to finish normally.
ERROR PARAMETER	Appears when a command's parameter value is invalid.
ERROR EEPROM	Appears when an error occurs while reading or writing a parameter in EEPROM.
ERROR EXECUTE	Appears when an over-detection error occurs during WPC-EXE execution.
ERROR BUSY	Appears when a command is sent to the camera before the response status for the previous command has been returned. This message is not displayed until at least 40 ms after the previous ERROR BUSY was returned.
(Current setting value)	Sending a parameter setting command with no parameter causes the current setting value to be displayed. Sending the HELP command with no parameter displays the command list.
AWB OK	Appears when One-Push AWB execution succeeds.

Response Status	Description
AWB TIMEOUT	Appears when One-Push AWB execution times out.
AWB ERROR	Appears when One-Push AWB execution fails.

# Camera Control Command List

Category	Command	Setting Value			Color Bar <sup>4)</sup> Displaying
		INIT Object <sup>1)</sup>	SAVE Object <sup>2)</sup>	Auto Saving <sup>3)</sup>	
AE	AE-MODE	○	○	×	×
	AGCMAX-STEP	○	○	×	×
	AGCMAX-FINE	○	○	×	×
	CCDIRIS-MAX	○	○	×	×
	SSHUTTER-MAX	○	○	×	×
	AE-SPEED	○	○	×	×
	AE-REF	○	○	×	×
	GAIN-STEP	○	○	×	×
	GAIN-FINE	○	○	×	×
	SHUTTER	○	○	×	×
	SSHUTTER	○	○	×	×
WB	WB-MODE	○	○	×	×
	AUTOWB	×	×	×	×
	RGAIN	○	○	×	×
	BGAIN	○	○	×	×
	ATW-SPEED	○	○	×	×
	CRS-MODE	○	○	×	×
PICTURE	DTL-MODE	○	○	×	×
	DTL-ENHANCER	○	○	×	×
	2DNR-MODE	○	○	×	×
	3DNR-MODE	○	○	×	×
	PEDESTAL	○	○	×	×
	GAMMA-MODE	○	○	×	×
	NEGAPOSI	○	○	×	×
	WHITECLIP	○	○	×	×
WPC	WPC-MODE	○	○	×	×
	WPC-EXE	×	×	×	×
	WPC-DISP	○	×	×	×
OPD	OPD-DISP	○	×	×	×
	OPD-AE-POS	○	○	×	×
	OPD-AE-SIZE	○	○	×	×
	OPD-AWB-POS	○	○	×	×
	OPD-AWB-SIZE	○	○	×	×



Category	Command	Setting Value			Color Bar <sup>4)</sup> Displaying
		INIT Object <sup>1)</sup>	SAVE Object <sup>2)</sup>	Auto Saving <sup>3)</sup>	
I / O	VOUTSEL	○	○	×	○
	HPHASE	○	○	×	○
	VPHASE	○	○	×	○
	COLORBAR	○	×	×	○
	FLIP	○	○	×	○
	BRATE	×	×	○	○
	OSD	○	○	×	○
	MEMO-CAPTURE	×	×	×	○
	MEMO-DISPLAY	○	×	×	○
Other	INIT	×	×	×	○
	SAVE	×	×	×	○
	LOAD	×	×	○	○
	RMEM	×	×	×	○
	VERSION	×	×	×	○
	HELP	×	×	×	○

1) The INIT command initializes this command's setting.

2) The SAVE and LOAD commands apply to this command's setting.

3) When this command is sent, its setting is automatically saved to EEPROM.

4) Commands are limited when the color bar is displayed: AE, WB, PICTURE, WPC, and OPD category commands return status errors.

# Camera Control Commands

Camera control commands are categorized as follows:

AE (Auto Exposure): Auto-exposure setting (page 18)

WB (White Balance): White balance setting (page 20)

PIC (Picture): Sharpness (aperture compensation), noise reduction, and video process settings (page 21)

WPC (White Pixel Compensation): White point detection and compensation settings (page 22)

OPD (Optical Detector): AE and AWB detection frame settings (page 23)

IN/OUT: Input/output settings (page 23)

MEMO: Memo function settings (page 24)

## AE (Auto Exposure)

### AE Operation Mode Setting

Command Name	AE-MODE
Parameter 1	Operation Mode, 0 to 5 0: Fixed electronic shutter + fixed gain 1: Fixed electronic slow shutter + fixed gain 2: Fixed electronic shutter + AGC 3: CCD IRIS 4: CCD IRIS + Auto slow shutter 5: CCD IRIS + AGC Default is Mode 2
Conditions	None
Process	0 and 1 select the ME operation mode, and other values set the AE mode.

### AGC Maximum Gain Setting (STEP)

Command Name	AGCMAX-STEP
Parameter 1	Gain: 6 to 18 [dB] Default is 18 [dB]
Conditions	Valid when AE-MODE parameter 2 and 5.
Process	Sets the upper gain limit for AGC.

### AGC Maximum Gain Setting (FINE)

Command Name	AGCMAX-FINE
Parameter 1	Gain: 22 to 67 Default is 67
Conditions	Valid when AE-MODE parameter 2 and 5.
Process	Sets the upper gain limit for AGC.

The relationship between gain and fine settings are as follows:

FINE Setting	Gain (dB)
22	6
26	7
30	8
33	9
37	10
41	11
44	12
48	13
52	14
56	15
59	16
63	17
67	18

### CCD Iris Electronic Shutter Maximum Speed Setting

Command Name	CCDIRIS-MAX
Parameter 1	Max. electronic shutter speed: 0 to 8 0: 1/100 [s] 1: 1/120 [s] 2: 1/250 [s] 3: 1/500 [s] 4: 1/1000 [s] 5: 1/4000 [s] 6: 1/10000 [s] 7: 1/50000 [s] 8: 1/100000 [s] Default is 5
Conditions	Valid when AE-MODE is 3 to 5.
Process	Sets the maximum speed of auto electronic shutter control.

## Slow Shutter Maximum Frame Count Setting

<b>Command Name</b>	<b>SSHUTTER-MAX</b>
Parameter 1	Max. frame count: 1 to 255 Default is 6 [frames]
Conditions	Valid when AE-MODE is 4.
Process	Sets the maximum accumulatable frame count for auto slow shutter.

### Note

The white point is higher with larger frame count settings, but this is an artifact of the CCD and not a defect.

## AE Convergence Speed Setting

<b>Command Name</b>	<b>AE-SPEED</b>
Parameter 1	Convergence speed: 0 to 2 0: Slow 1: Normal 2: Fast Default is 1
Conditions	Valid when AE-MODE is 2 to 5.
Process	Sets the AE convergence speed.

## AE Reference Level Setting

<b>Command Name</b>	<b>AE-REF</b>
Parameter 1	Reference Level: 0 to 1023 0: Minimum to 100: Standard to 1023: Maximum Default is 120
Conditions	Valid when AE-MODE is 2 to 5.
Process	Sets the AE reference level

## Fixed Step Gain Setting (STEP)

<b>Command Name</b>	<b>GAIN-STEP</b>
Parameter 1	Gain: -3 to +18 [dB] Default is 0 [dB]
Conditions	Valid when AE-MODE is 0 to 1.
Process	Sets fixed AGC gain.

## Fixed Step Gain Setting (FINE)

<b>Command Name</b>	<b>GAIN-FINE</b>
Parameter 1	Gain: -79 to +474 Default is 0
Conditions	Valid when AE-MODE is 0 to 1.
Process	Sets fixed AGC gain.

The relationship between gain and fine settings are as follows:

<b>FINE Setting</b>	<b>Gain (dB)</b>
-79	-3
-53	-2
-26	-1
0	0
26	1
53	2
79	3
105	4
132	5
158	6
184	7
211	8
237	9
263	10
289	11
316	12
342	13
368	14
395	15
421	16
447	17
474	18

## Fixed Electronic Shutter Speed Setting

Command Name	SHUTTER
Parameter 1	Electronic shutter speed: 0 to 12 0: OFF (1/60 [s] for NTSC, 1/50 [s] for PAL) 1: 1/100 [s] (Flickerless NTSC operation) 2: 1/120 [s] (Flickerless PAL operation) 3: 1/250 [s] 4: 1/500 [s] 5: 1/1000 [s] 6: 1/2000 [s] 7: 1/4000 [s] 8: 1/10000 [s] 9: 1/50000 [s] 10: 1/100000 [s] 11: Arbitrary electronic shutter setting Default is 0
Parameter 2	This is the electronic shutter speed adjustment value when parameter 1 is "11: Arbitrary electronic shutter setting" NTSC: 0 to 261 PAL: 0 to 311
Parameter 3	This is the electronic shutter fine adjustment value when parameter 1 is "11: Arbitrary electronic shutter setting" NTSC: 0 to 910 PAL: 0 to 908 However, when parameter 2 is 0 (NTSC or PAL), the range for this parameter is as follows: NTSC: 143 to 910 PAL: 142 to 908
Conditions	Valid when AE-MODE is 0 and 2.
Process	Sets the AE electronic shutter speed When parameter 1 is set to "11: Arbitrary electronic shutter setting," electronic shutter timing is calculated as follows: NTSC: (parameter 2) × 63.49 [μs] + (parameter 3) × 69.84 [ns] PAL: (parameter 2) × 64.00 [μs] + (parameter 3) × 70.48 [ns]

## Fixed Electronic Slow Shutter Speed Setting

Command Name	SSHUTTER
Parameter 1	Fixed electronic slow shutter adjustment value NTSC: 0 to 255 PAL: 0 to 255 Default is 3
Parameter 2	Fixed electronic slow shutter fine adjustment value NTSC: 0 to 524 PAL: 0 to 624 However, when parameter 1 is 0 (NTSC or PAL), the range for this parameter is as follows: NTSC: 262 to 524 PAL: 312 to 624
Conditions	Valid when AE-MODE is 1.
Process	The fixed electronic slow shutter time is calculated as follows: NTSC: (parameter 1) × 33.268 [ms] + (parameter 2) × 63.49 [μs] PAL: (parameter 1) × 39.936 [ms] + (parameter 2) × 64.00 [μs]

## WB (White Balance)

### WB Mode Setting

Command Name	WB-MODE
Parameter 1	WB Mode: 0 to 4 0: One Push AWB 1: ATW 2: Manual 3: Preset 3200K 4: Preset 5600K Default is 1
Conditions	None
Process	Sets the WB mode.

### Manual R Gain Setting

Command Name	RGAIN
Parameter 1	R gain: 0 to 4095 0: Minimum 4095: Maximum Default R gain is 3200K
Conditions	Valid when WB-MODE is 2.
Process	Sets the R gain when WB Mode is "2: Manual."

## Manual B Gain Setting

<b>Command Name</b>	<b>BGAIN</b>
Parameter 1	B gain: 0 to 4095 0: Minimum to 4095: Maximum Default B gain is 3200K
Conditions	Valid when WB-MODE is 2.
Process	Sets the B gain when WB Mode is "2: Manual."

## One-Push AWB Execution

<b>Command Name</b>	<b>AUTOWB</b>
Parameter	None
Conditions	Valid when WB-MODE is 0.
Process	Starts One-Push AWB processing. When processing is finished, one of the following is returned: AWB OK: Normal finish AWB TIMEOUT: Time-out failure AWB ERROR: Other failure

## ATW Entrainment Speed Setting

<b>Command Name</b>	<b>ATW-SPEED</b>
Parameter 1	Entrainment speed: 0 to 2 0: Slow 1: Normal 2: Fast Default is 1
Conditions	Valid when WB-MODE is 1.
Process	Sets the entrainment speed for ATW/CRS.

## CRS Setting during ATW

<b>Command Name</b>	<b>CRS-MODE</b>
Parameter 1	CRS Mode, 0 to 1 0: OFF 1: ON Default is 0
Conditions	Valid when WB-MODE is 1.
Process	Enables or disables the CRS function.

## PIC (Picture)

### Aperture Compensation Mode Setting

<b>Command Name</b>	<b>DTL-MODE</b>
Parameter 1	Aperture Compensation Mode: 0 to 4 0: Off 1: Vertical aperture compensation 2: Horizontal aperture compensation 3: Vertical + horizontal aperture compensation 4: Highlight aperture compensation Default is 2
Conditions	None
Process	Sets the aperture compensation mode. Increases sharpness by emphasizing image contours.

### Detail Enhancer Setting

<b>Command Name</b>	<b>DTL-ENHANCER</b>
Parameter 1	Detail enhancer enable/disable setting: 0 to 1 0: OFF 1: ON Default is 0
Conditions	None
Process	Enhances signal details that may be obscured by normal contour emphasis (aperture compensation) processing.

### 2D-NR Setting

<b>Command Name</b>	<b>2DNR-MODE</b>
Parameter 1	Filter selection: 0 to 3 0: 2D-NR disabled 1: Mild 2D-NR 2: Moderate 2D-NR 3: Strong 2D-NR Default is 1
Conditions	None
Process	Sets the strength of 2D-NR noise suppression. Higher noise suppression corresponds to lower resolution. The 2D-NR function performs spatial filtering on an image to suppress noise effects within a specific range.

### 3D-NR Setting

<b>Command Name</b>	<b>3DNR-MODE</b>
Parameter 1	Filter selection: 0 to 3 0: 3D-NR disabled 1: Mild 3D-NR 2: Moderate 3D-NR 3: Strong 3D-NR Default is 0
Conditions	None
Process	Sets the strength of 3D-NR noise suppression. Higher noise suppression corresponds to lower dynamic resolution as the afterimage becomes more visible.

### Pedestal Setting

<b>Command Name</b>	<b>PEDESTAL</b>
Parameter 1	0 to 22 (corresponds to NTSC: 0 to 10 [IRE], and PAL: PAL 0 to 70 [mV]) Default is 11 (NTSC: 5 [IRE], and PAL: 35 [mV])
Conditions	None
Process	Adjusts the pedestal. Does not affect gamma-curve compensation.

### Gamma Table Setting

<b>Command Name</b>	<b>GAMMA-MODE</b>
Parameter 1	Gamma curve: 0 to 2 0: $\gamma = 1.0$ 1: $\gamma = 0.45(\gamma = 1/2.2)$ 2: $\gamma = 0.6(\gamma = 1/1.6)$ Default is 1
Conditions	None
Process	Specifies the gamma curve of the YC signal (the specified C is used regardless of the GAMMA-MODE setting.)

### Polarity (Nega/Posi) Setting

<b>Command Name</b>	<b>NEGAPOSI</b>
Parameter 1	Polarity: 0 to 1 0: Positive 1: Negative Default is 0
Conditions	None
Process	Inverts the YC signal after gamma curve compensation.

### High Brightness Clipping Setting

<b>Command Name</b>	<b>WHITECLIP</b>
Parameter 1	Brightness signal clipping level: 0 to 63 0: Minimum to 1: Maximum (no clipping) Default is 63
Conditions	None
Process	Clips brightness exceeding the specified level in the final output of the Y signal. Use this function to avoid image whiteout.

### WPC (White Pixel Compensation)

#### Enable/Disable White Point Detection Compensation

<b>Command Name</b>	<b>WPC-MODE</b>
Parameter 1	White point detection compensation enable/disable: 0 to 1 0: OFF 1: ON Default is 1
Conditions	None
Process	Enables or disables auto detection of white point compensation.

#### Execute Auto White Point Detection

<b>Command Name</b>	<b>WPC-EXE</b>
Parameter	None
Conditions	None
Process	Starts auto white point detection processing. Execute with the lens covered, such as by a lens cap.

#### White Point Compensation Marker Setting

<b>Command Name</b>	<b>WPC-DISP</b>
Parameter 1	Marker display/non-display: 0 to 1 0: OFF 1: ON Default is 0
Conditions	Display is only possible when WPC-MODE is 1.
Process	The marker indicates the white point location on the object of compensation.

## OPD (Optical Detector)

### OPD Frame Display Setting

Command Name	OPD-DISP
Parameter 1	OPD frame display: 0 to 2 0: OFF 1: AE 2: AWB Default is 0
Conditions	None
Process	Displays the detection frame for AE or AWB.

### OPD-AE Position Setting

Command Name	PD-AE-POS
Parameter 1	X-coordinate of center of OPD frame [%] Settable range is 25 to 75 Default is 50
Parameter 2	Y-coordinate of center of OPD frame [%] Settable range is 25 to 75 Default is 50
Conditions	None
Process	Sets the position of the AE detection frame.

### OPD-AE Size Setting

Command Name	OPD-AE-SIZE
Parameter 1	OPD frame width Settable range is 50 to 100 Default is 50
Parameter 2	Y-coordinate of center of OPD frame [%] Settable range is 50 to 100 Default is 50
Conditions	None
Process	Sets the size of the AE detection frame.

### OPD-AWB Position Setting

Command Name	OPD-AWB-POS
Parameter 1	X-coordinate of center of OPD frame [%] Settable range is 25 to 75 Default is 50
Parameter 2	Y-coordinate of center of OPD frame [%] Settable range is 25 to 75 Default is 50
Conditions	None
Process	Sets the position of the AWB detection frame.

### OPD-AWB Size Setting

Command Name	OPD-AWB-SIZE
Parameter 1	OPD frame width Settable range is 50 to 100 Default is 50
Parameter 2	Y-coordinate of center of OPD frame [%] Settable range is 50 to 100 Default is 50
Conditions	None
Process	Sets the size of the AWB detection frame.

## IN/OUT

### VBS/YC Output Selection

Command Name	VOUTSEL
Parameter 1	Output signal: 0 to 1 0: VBS 1: Y/C Default is 0
Conditions	None
Process	Selects VBS or YC output signal format.

### H-Phase Setting

Command Name	HPHASE
Parameter 1	H-phase setting value: 0 to 910 (NTSC) 0 to 908 (PAL) Default is 104
Conditions	Valid only when the camera is operated with external synchronization.
Process	Sets the H-phase adjustment value when using external synchronization.

### V-Phase Setting

Command Name	VPHASE
Parameter 1	V-phase setting value: 0 to 262 (NTSC) 0 to 312 (PAL) Default is 10
Conditions	Valid only when the camera is operated with external synchronization.
Process	Sets the V-phase adjustment value when using external synchronization.

## Internal Color Bar Output Setting

<b>Command Name</b>	<b>COLORBAR</b>
Parameter 1	Color bar output setting ON/OFF: 0 to 1 0: ON 1: OFF Default is 0
Conditions	None
Process	Enables or disables color bar output. When ON, the display shows 100% color bars.

## Flip Output Setting

<b>Command Name</b>	<b>FLIP</b>
Parameter 1	Flip setting: 0 to 3 0: OFF 1: Flip horizontally 2: Flip vertically 3: Flip horizontally and vertically Default is 0
Conditions	None
Process	Sets the flip output mode. The output image can be flipped horizontally and vertically.

## Serial Communication Speed Setting

<b>Command Name</b>	<b>BRATE</b>
Parameter 1	Baud rate: 0 to 2 0: 9600 [bps] 1: 19200 [bps] 2: 38400 [bps] Default is 2
Conditions	None
Process	Sets the serial communication speed. Unique to this command, the baud rate is changed after the "OK" response has been sent.

## OSD Output Setting

<b>Command Name</b>	<b>OSD</b>
Parameter 1	OSD output ON/OFF setting: 0 to 1 0: OFF 1: ON Default is 0
Conditions	None
Process	Sets the OSD output mode.
Remarks	The only command with OSD output is AUTOWB (One Push).

## MEMO

### Memo Saving

<b>Command Name</b>	<b>MEMO-CAPTURE</b>
Parameter 1	Memo save destination: 0 to 1 0: Memo 1 1: Memo 2 Default is 0
Conditions	Saving is available only when MEMO-DISPLAY is "1: Still Image". Otherwise, ERROR STATUS is returned.
Process	Saves a still image as a memo.
Remarks	The memo image is lost when power turns off.

### Memo Display

<b>Command Name</b>	<b>MEMO-DISPLAY</b>
Parameter 1	Display selection: 0 to 3 0: Native image 1: Still image 2: Memo 1 image 3: Memo 2 image Default is 0
Conditions	Memo 1 and 2 images are not selectable until saved (ERROR STATUS is returned). Switching from a memo image to another still image is not possible.
Process	Selects the image for output.
Remarks	The Still function can capture the processed image of internal color bars and the OPD frame state.

## Miscellaneous

### Setting Value Control Commands

The setting value control commands control camera setting data stored in the EEPROM. The following command types are available:

Type	Description
Setting Initialization	Resets user's camera control settings to their factory default values.
Setting Saving	Writes user's camera control settings to the EEPROM.
Setting Loading	Loads user's camera control settings from the EEPROM.
View Setting Values	Displays the current user settings for each command.



## Settings Affected by INIT, SAVE, and LOAD Commands

The following commands apply to camera setting data.

Command	Remarks
AE-MODE	INIT initializes to fixed value.
AGCMAX-STEP	INIT initializes to fixed value.
AGCMAX-FINE	INIT initializes to fixed value.
CCDIRIS-MAX	INIT initializes to fixed value.
SSHUTTER-MAX	INIT initializes to fixed value.
AE-SPEED	INIT initializes to fixed value.
AE-REF	INIT initializes to fixed value.
GAIN-STEP	INIT initializes to fixed value.
GAIN-FINE	INIT initializes to fixed value.
SHUTTER	INIT initializes to fixed value.
WB-MODE	INIT initializes to fixed value.
RGAIN	INIT initializes to factory default value.
BGAIN	INIT initializes to factory default value.
ATW-SPEED	INIT initializes to fixed value.
CRS-MODE	INIT initializes to fixed value.
DTL-MODE	INIT initializes to fixed value.
DTL-ENHANCER	INIT initializes to fixed value.
2DNR-MODE	INIT initializes to fixed value.
3DNR-MODE	INIT initializes to fixed value.
PEDESTAL	INIT initializes to fixed value.
GAMMA-MODE	INIT initializes to fixed value.
NEGAPOSI	INIT initializes to fixed value.
WHITECLIP	INIT initializes to fixed value.
WPC-MODE	INIT initializes to fixed value.
OPD-DISP	INIT initializes to fixed value.
OPD-AE-POS	INIT initializes to fixed value.
OPD-AE-SIZE	INIT initializes to fixed value.
OPD-AWB-POS	INIT initializes to fixed value.
OPD-AWB-SIZE	INIT initializes to fixed value.
VOUTSEL	INIT initializes to fixed value.
HPHASE	INIT initializes to factory default value.
VPHASE	INIT initializes to factory default value.
COLORBAR	INIT initializes to fixed value.
FLIP	INIT initializes to fixed value.
OSD	INIT initializes to fixed value.
MEMO-DISPLAY	INIT initializes to fixed value.

## Setting Value Initialization

Command Name	INIT
Parameter	None
Conditions	None
Process	Returns the camera's user memory to its factory default state. The last loaded user memory is not changed.
Remarks	The communication speed is not initialized.

## Setting Value Saving

Command Name	SAVE
Parameter 1	User memory save destination: 0 to 1 0: User memory A 1: User memory B
Conditions	None
Process	Writes to user memory A or B.

## Setting Value Loading

Command Name	LOAD
Parameter 1	Load original user memory: 0 to 2 0: User memory A 1: User memory B 2: Stand-alone user memory
Conditions	None
Process	Loads user's camera control command settings, and saves them as the last loaded user memory selection information. These user memory settings are loaded the next time the camera is turned on.

## View Setting Values

Command Name	RMEM
Parameter	None
Conditions	None
Process	Sends all data that can be set with camera information. The setting value of each camera control command is displayed one command per line, with comma separators.

## Version Display

Command Name	VERSION
Parameter	None
Conditions	None
Process	Displays the following items: <ul style="list-style-type: none"> <li>• Camera model name</li> <li>• Firmware version</li> <li>• Serial number</li> </ul>

<<Input>>

```
VERSION<CR>
```

<<Screen Output Example (NTSC)>>

```
XC-505<CR><LF>
Version 1.00<CR><LF>
S/N 100001<CR><LF>
```

<<Screen Output Example (PAL)>>

```
XC-505P<CR><LF>
Version 1.00<CR><LF>
S/N 100001<CR><LF>
```

## Help Display

Command Name	HELP
Parameter 1	Command Name
Conditions	None
Process	Display help for the command specified by parameter 1. If parameter 1 is omitted, displays the list of usable commands.

```
HELP
AE-MODE,
AGCMAX-STEP,
AGCMAX-FINE,
CCDIRIS-MAX,
SSHUTTER-MAX,
AE-SPEED,
AE-REF,
GAIN-STEP,
GAIN-FINE,
SHUTTER,
SSHUTTER,
WB-MODE,
AUTOWB,
RGAIN,
BGAIN,
ATW-SPEED,
CRS-MODE,
PICTURE,
DTL-MODE,
DTL-ENHANCER,
```

```
2DNR-MODE,
3DNR-MODE,
PEDESTAL,
GAMMA-MODE,
NEGAPOSI,
WHITECLIP,
WPC-MODE,
WPC-DISP,
WPC-EXE,
OPD-DISP,
OPD-AE-POS,
OPD-AE-SIZE,
OPD-AWB-POS,
OPD-AWB-SIZE,
VOUTSEL,
HPHASE,
VPHASE,
COLORBAR,
FLIP,
BRATE,
OSD,
MEMO-CAPTURE,
MEMO-DISPLAY,
INIT,
SAVE,
LOAD,
RMEM,
VERSION,
HELP
OK
```

## Camera Control Command List

For parameters 1 and 2, numerical values in parenthesis ( ) indicate default values.

Category	INIT Object	SAVE Object	Auto Save	Command	Command String	Parameter 1	Parameter 2	Parameter 3	Remarks
AE	○	○	×	Auto exposure mode setting	AE-MODE	Mode0 to 5 (2) 0 : Fixed electronic shutter 1 : Fixed electronic shutter + fixed gain 2 : Fixed electronic slow shutter + fixed gain 3 : CCD IRIS 4 : CCD IRIS + Auto slow shutter 5 : CCD IRIS + AGC	×	×	
	○	○	×	Max. auto gain control setting (dB)	AGCMAX-STEP	dB units 6 to 18 (18)	×	×	AGCMAX-STEP and AGCMAX-FINE values are linked
	○	○	×	Max. auto gain control setting (step)	AGCMAX-FINE	Step units 22 to 67 (67)	×	×	AGCMAX-STEP and AGCMAX-FINE values are linked
	○	○	×	Electronic shutter max. adjustment value	CCDIRIS-MAX	Preset Number 0 to 8 (5) 0 : 1/100s 1 : 1/120s 2 : 1/250s 3 : 1/500s 4 : 1/1000s 5 : 1/4000s 6 : 1/10000s 7 : 1/50000s 8 : 1/100000s	×	×	
	○	○	×	Slow shutter max. adjustment value	SSHUTTER-MAX	Frame count 1 to 255 (6)	×	×	
	○	○	×	AE Convergence Speed Setting	AE-SPEED	Speed (Slow/Normal/Fast) 0, 1, 2 (1)	×	×	
	○	○	×	AE Reference Level Setting	AE-REF	Reference Level 0 to 1023 (120)	×	×	
	○	○	×	Gain setting (dB)	GAIN-STEP	dB units -3 to 18 (0)	×	×	GAIN-STEP and GAIN-FINE values are linked
	○	○	×	Gain setting (step)	GAIN-FINE	Step units -79 to 474 (0)	×	×	GAIN-STEP and GAIN-FINE values are linked

Category	INIT Object	SAVE Object	Auto Save	Command	Command String	Parameter 1	Parameter 2	Parameter 3	Remarks
AE	○	○	×	Fixed electronic shutter speed	SHUTTER	Preset Number	Arbitrary Parameter 1	Arbitrary Parameter 2	
						NTSC (0) 0 : 1/60s 1 : 1/100s 2 : 1/120s 3 : 1/250s 4 : 1/500s 5 : 1/1000s 6 : 1/2000s 7 : 1/4000s 8 : 1/10000s 9 : 1/50000s 10 : 1/100000s  PAL(0) 0 : 1/50s 1 : 1/100s 2 : 1/120s 3 : 1/250s 4 : 1/500s 5 : 1/1000s 6 : 1/2000s 7 : 1/4000s 8 : 1/10000s 9 : 1/50000s 10 : 1/100000s	×	×	
				11	0 to 261 NTSC 0 to 311 PAL	0 to 910 NTSC 0 to 908 PAL	NTSC When parameter 2 is 0, the range for parameter 3 is 143 to 910.  PAL When parameter 2 is 0, the range for parameter 3 is 142 to 908.		
				Fixed electronic slow shutter speed	SSHUTTER	0 to 255 (3) NTSC 0 to 255 (3) PAL	0 to 524 (0) NTSC 0 to 624 (0) PAL	×	NTSC When parameter 1 is 0, the range for parameter 2 is 262 to 524.  PAL When parameter 1 is 0, the range for parameter 2 is 312 to 624.
WB	○	○	×	White balance mode setting	WB-MODE	One Push/ATW/Manual/3200K/5600K 0,1,2,3,4(1)	×	×	
	×	×	×	One Push white balance execution	AUTOWB	×	×	×	Only when WB-MODE = 0
	○	○	×	Manual R gain	RGAIN	Step units 0 to 4095 (factory)	×	×	Only when WB-MODE = 2 Default R gain is 3200 [K].
	○	○	×	Manual B gain	BGAIN	Step units 0 to 4095 (factory)	×	×	Only when WB-MODE = 2 Default B gain is 3200 [K].
	○	○	×	ATW Entrainment speed adjustment	ATW-SPEED	Speed (Slow/Normal/Fast) 0,1,2 (1)	×	×	

Category	INIT Object	SAVE Object	Auto Save	Command	Command String	Parameter 1	Parameter 2	Parameter 3	Remarks
WB	○	○	×	Switch CRS during ATW	CRS-MODE	Mode (Off/On) 0,1 (0)	×	×	Only when WB-MODE = 1
PICTURE	○	○	×	Contour emphasis mode	DTL-MODE	MODE (Off, V, H, V+H, Highlight) 0,1,2,3,4 (2)	×	×	
	○	○	×	Detail enhancer	DTL-ENHANCER	Mode (Off/On) 0,1 (0)	×	×	
	○	○	×	2-D noise reduction setting	2DNR-MODE	Off, Mild, Moderate, Strong 0,1,2,3 (1)	×	×	
	○	○	×	3-D noise reduction setting	3DNR-MODE	Off, Mild, Moderate, Strong 0,1,2,3 (0)	×	×	
	○	○	×	Pedestal adjustment	PEDESTAL	Step units 0 to 22 (11)	×	×	
	○	○	×	Gamma compensation setting	GAMMA-MODE	Off/ $\gamma$ = 0.45/ $\gamma$ = 0.60 0,1,2 (1)	×	×	
	○	○	×	Positive-negative reverse	NEGAPOSI	Positive/Negative 0,1 (0)	×	×	
	○	○	×	High Brightness Clipping Setting	WHITECLIP	Step units 0 to 63 (63)	×	×	
WPC	○	○	×	White point detection mode	WPC-MODE	Mode (Off/On) 0,1 (1)	×	×	
	×	×	×	Auto white point detection compensation execution	WPC-EXE	×	×	×	Execute with the lens covered, such as by a lens cap.
	○	×	×	White point compensation position default is 0	WPC-DISP	OFF/ON 0,1 (0)	×	×	Displays only when WPC-MODE is 1.
OPD	○	×	×	Detection frame display switching	OPD-DISP	Off/AE/WB 0,1,2 (0)	×	×	
	○	○	×	AE frame center coordinates	OPD-AE-POS	x-coordinate 25 to 75 (50)	y-coordinate 25 to 75 (50)	×	
	○	○	×	AE frame width and height	OPD-AE-SIZE	width 50 to 100 (50)	height 50 to 100 (factory)	×	
	○	○	×	AWB frame center coordinates	OPD-AWB-POS	x-coordinate 25 to 75 (50)	y-coordinate 25 to 75 (50)	×	
	○	○	×	AWB frame width and height	OPD-AWB-SIZE	width 50 to 100 (50)	height 50 to 100 (50)	×	

Category	INIT Object	SAVE Object	Auto Save	Command	Command String	Parameter 1	Parameter 2	Parameter 3	Remarks
I/O	○	○	×	VBS/YC Output Selection	VOUTSEL	VBS or separate Y/C 0,1(0)	×	×	
	○	○	×	Horizontal phase adjustment	HPHASE	Adjustment Step 0 to 910 (factory) NTSC 0 to 908 (factory) PAL	×	×	
	○	○	×	Vertical phase adjustment	VPHASE	Adjustment Step 0 to 262 (factory) NTSC 0 to 312 (factory) PAL	×	×	
	○	×	×	Color bar output	COLORBAR	Off/On 0,1 (0)	×	×	
	○	○	×	Reverse image display	FLIP	Reverse mode (None, horizontal, vertical, 180 deg.) 0,1,2,3 (0)	×	×	
	×	×	○	Serial communication speed changing	BRATE	Baud rate selection (9600/19200/38400) 0,1,2 (2)	×	×	
	○	○	×	OSD Display	OSD	Off/On 0,1	×	×	
	×	×	×	Screen memo saving	MEMO-CAPTURE	Save destination (0 or 1) 0,1 (0)	×	×	Saving is possible with still image displayed
	○	×	×	Memo Display	MEMO-DISPLAY	Off/still/memo1/ memo2 0,1,2,3 (0)	×	×	
Miscellaneous	×	×	×	Setting Value Initialization	INIT	×	×	×	
	×	×	×	Setting Value Saving	SAVE	Save destination selection (A or B) 0,1	×	×	
	×	×	○	Load settings from destination upon next restart	LOAD	Load source selection (A, B, or stand-alone) 0,1,2 (2)	×	×	Subsequently starts from last loaded slot
	×	×	×	Read setting values	RMEM	×	×	×	
	×	×	×	Version Display	VERSION	×	×	×	
	×	×	×	Help Display	HELP	Command Name string	×	×	Lists commands when parameter 1 is omitted

# Specifications

## Photographic Components

Image sensor	1/3-type interline transfer CCD
Color filter	Complementary color mosaic
Effective pixels	XC-505: Approx. 380,000 dots (768 [H] × 494 [V]) XC-505P: Approx. 440,000 dots (752 [H] × 582 [V])
Video output pixels	XC-505: 756 [H] × 485 [V] XC-505P: 739 [H] × 575 [V]
Cell size	XC-505: 6.35 [H] × 7.40 [V] μm XC-505P: 6.50 [H] × 6.25 [V] μm

## Optics & Miscellaneous

Lens mount	Dedicated (NF) mount
Signal format	XC-505: EIA standard NTSC color XC-505P: CCIR standard PAL color
Scan format	XC-505: 525 lines, 2:1 interlace, 30 frames/s XC-505P: 625 lines, 2:1 interlace, 25 frames/s
Sync method	Internal or external (auto-switching)
External sync input	HD/VD or VS
Horizontal resolution	XC-505: 470 TV lines XC-505P: 460 TV lines
Minimum illumination	1.5 lx (F1.4, AGC: ON)
Sensitivity	2000 lx (F11, AGC: OFF [0 dB])
Video output	VBS or Y/C (switch-selectable) VBS: 1 V <sub>p-p</sub> , 75 Ω, negative sync Y: 1 V <sub>p-p</sub> , 75 Ω C: composite video output dependent
Video S/N	XC-505: 48 dB (standard), AGC: OFF (0 dB) XC-505P: 46 dB (standard), AGC: OFF (0 dB)
Shutter speed (4 modes)	1/60 s (OFF): XC-505 1/50 s: XC-505P (OFF), 1/1000 s, CCD IRIS, and Flickerless (1/00)
CCD IRIS	XC-505: 1/60 s to 1/4000 s XC-505P: 1/50 s to 1/4000 s
White balance (5 modes)	ATW, One Push WB, 3200K, 5600K, and MAN
Gain control (2 modes)	AGC (0 dB to 18 dB), and fixed (0 dB)

Output connector  
12-pin DC IN, SYNC, and VIDEO

## External VS (sync) input

Input level	XC-505: Video signal = 0 V <sub>pp</sub> to 1.4 V <sub>pp</sub> CSYNC signal = 0.15 V <sub>pp</sub> to 0.6 V <sub>pp</sub> XC-505P: Video signal = 0 V <sub>pp</sub> to 1.4 V <sub>pp</sub> CSYNC signal = 0.15 V <sub>pp</sub> to 0.6 V <sub>pp</sub>
Horizontal input frequency	XC-505: 15734 Hz ±0.236 Hz XC-505P: 15,625 Hz ±0.234 Hz
Vertical input frequency	XC-505: 59.94 Hz ±0.00089 Hz XC-505P: 50 Hz ±0.00075 Hz
Termination	Camera-internal 75 Ω
H jitter	20 ns or less

## External HD/VD sync input

Input level	same for XC-505 and XC-505P High: 4.0 V to 5.0 V DC Low: 0 V to 0.5 V DC Negative polarity
HD input frequency	XC-505: 15734 Hz ±0.236 Hz XC-505P: 15,625 Hz ±0.234 Hz
VD input frequency	XC-505: 59.94 Hz ±0.00089 Hz XC-505P: 50 Hz ±0.00075 Hz
Termination	Camera-internal 75 Ω
H jitter	20 ns or less

## General

Power requirement	10.5 V to 15 V DC
Power consumption	1.5 W
Operating temperature	0 °C to 40 °C (32 °F to 104 °F)
Storage temperature	-30 °C to +60 °C (-22 °F to +140 °F)
Operating humidity	20% to 80% (non-condensing)
Storage humidity	20% to 90% (non-condensing)
Shock resistance	70 G
MTBF	81,880 hours (approx. 9.3 years)

## Physical characteristics

Mass Approx. 51 g (1.8 oz)

Dimensions 22 (W) × 22 (H) × 64 (D) mm  
 (7/8 (W) × 7/8 (H) × 2<sup>5</sup>/<sub>8</sub> (D) inches)  
 (excluding protrusions)

### Supplied accessories

- Lens mount cap (1)
- Tripod adaptor (1 set)
- Operating Instructions (1)

### Optional accessories

- Camera adaptor DC-700, DC-700CE
- Compatible lenses
  - NF-mount
    - VCL-12S12XM (f=12 mm)
    - VCL-06S12XM (f=6 mm)
    - VCL-03S12XM (f=3.5 mm)
  - C-mount LO-999CMT
- Cable (12-pin) CCXC-12P02N (2 m)/12P05N (5 m)/12P10N (10 m)/12P25N (25 m)
- Angle case kit XCK-L555

Design and specifications are subject to change without notice.

## Dimensions

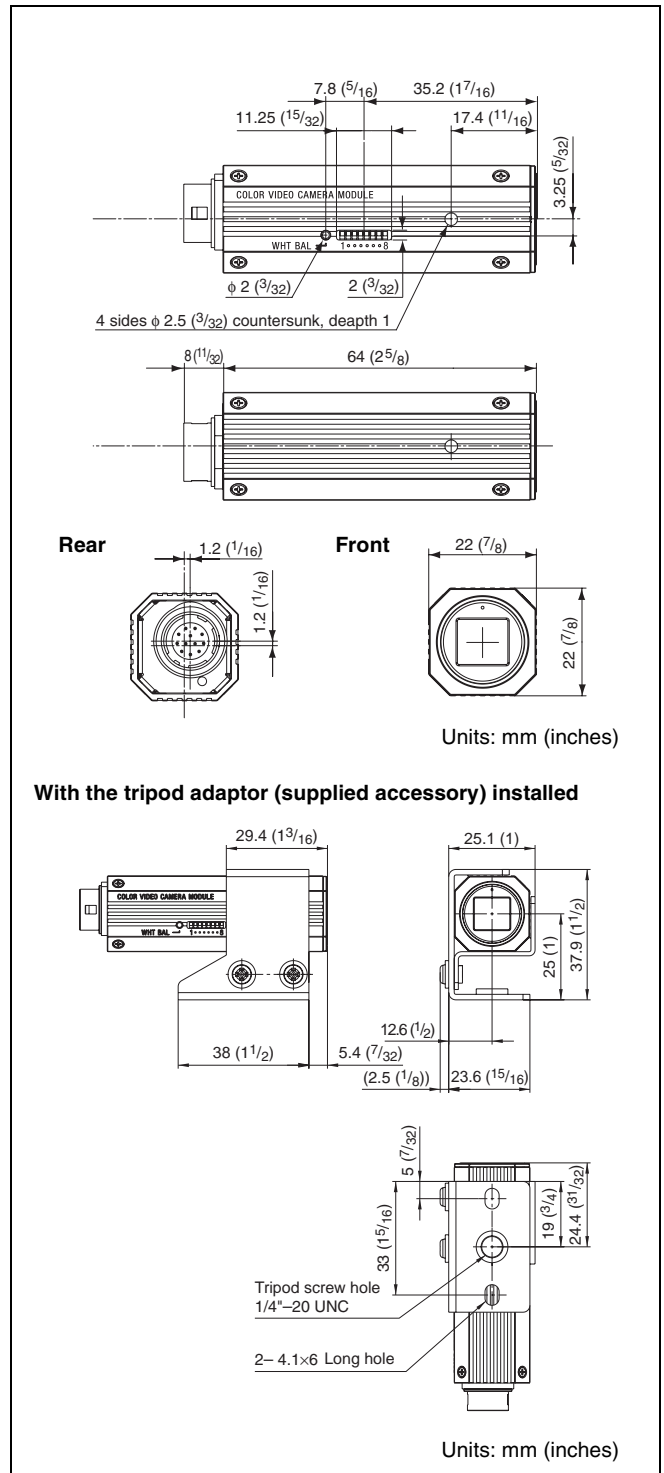



# Spectral Sensitivity Characteristics (typical)

## XC-505

Relative sensitivity

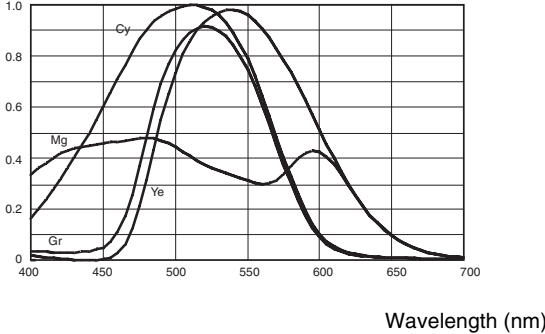

## XC-505P

Relative sensitivity

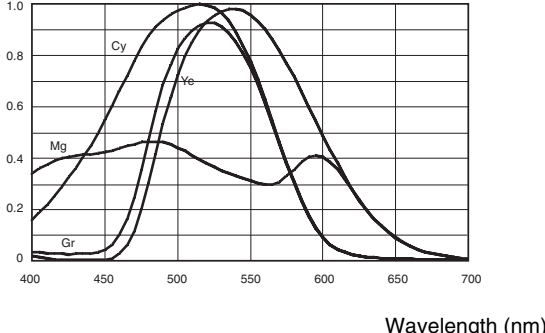

Characteristics of the lens and light source are excluded.

